

FITTING INSTRUCTION

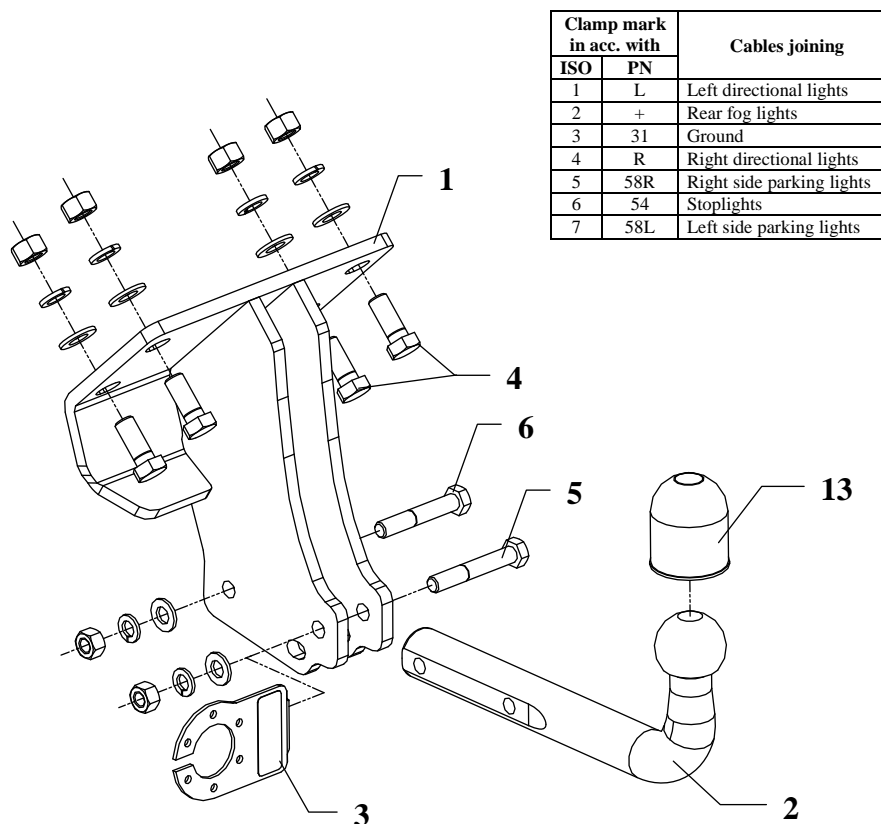

This towing hitch is designed to assembly in following cars: **MERCEDES G-Class, (W461, W463), except G-Modell 463 motor 350 Blue Tec**, produced since 12.1989, catalogue no. **D25** and is prepared to tow trailers max total weight **3500 kg** and max vertical mass **120 kg**.

From manufacturer

Thank you for buying our product. Their reliability has been confirmed in many tests. Reliability of towing hitch depends also on correct assembly and right operation. For this reasons we kindly ask to read carefully this instruction and apply to hints.

The towing hitch should be install in points described by a car producer.

The instruction of the assembly

1. Apply main plate of towbar (pos. 1) to the car this way, so holes of plate agree with holes in the car. Fix plate using 4 bolts M14x35mm (pos. 4) from accessories.
2. Fix tow-ball (pos. 2) with socket plate (pos. 3) using bolts M12x75mm (pos. 5) and M12x70mm (pos. 6) from accessories.
3. Tighten all bolts according to the torque shown in the table.
4. Connect electric wires of 7-poles socket according to the instruction of the car. (Recommend to make at authorized service station).
5. Complete paint layer damaged during installation.

Torque settings for nuts and bolts (8,8):

M6 - 11 Nm	M 8 - 25 Nm	M 10 - 50 Nm
M 12 - 87 Nm	M 14 - 138 Nm	M16 - 210 Nm









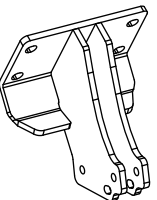
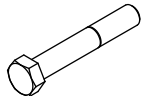

NOTE

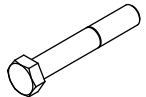
After install the towing hitch you should get adequate note in registration book (at authorised service station). The car should be equipped with:

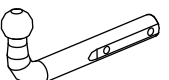
- Indicators
- Tow mirrors

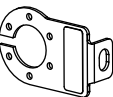
After 1000km of exploitation check all bolts and nuts. The ball of towing hitch must be always kept clear and conserve with a grease.

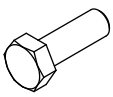
Towing hitch accessories:

Pos. 1 Main plate PCS.: 1 	Pos. 5 Bolt 8,8 B M12x75mm PCS.: 1 	Pos. 10 Spring washer ø12,2mm PCS.: 2 
	Pos. 6 Bolt 8,8 B M12x70mm PCS.: 1 	Pos. 11 Nut 8 B M14 PCS.: 4 
Pos. 2 Tow ball pcs.: 1 	Pos. 7 Plain washer ø15mm PCS.: 4 	Pos. 12 Nut 8 B M12 PCS.: 2 
Pos. 3 Socket plate pcs.: 1 	Pos. 8 Plain washer ø13mm PCS.: 2 	Pos. 13 Ball cover PCS.: 1 
Pos. 4 Bolt 8,8 B M14x35mm PCS.: 4 	Pos. 9 Spring washer ø14,2mm PCS.: 4 	



AUTO-HAK Sp. z o. o.

ul. Słoneczna 16K
76-200 SŁUPSK
tel./fax. 59 8 414 414; 59 8 414 413
E-mail: office@autohak.com.pl
www.autohak.com.pl

Towing hitch (without electrical set)

Class: **A50-X** Cat. no. **D25**

Designed for:

Manufacturer: **MERCEDES**

Model: **G-Class**

Type: (W461, W463), except G-Modell 463 motor 350 Blue Tec
produced since 12.1989

Technical data:

D-value: 13,6 kN

maximum trailer weight: **3500 kg**

maximum vertical cup mass: **120 kg**

Approval number according to Directive 94/20/EC: e20*94/20*0624*00

Foreword

This towing hitch is designed according to rules of safety traffic regulations. The towing hitch is a safety component and can be install only by qualified personnel. Any alteration or conversion of the towing hitch is prohibited and would lead to cancellation of design certification. Remove insulating compound and underseal from vehicle (if present) in the area of the matting surfaces of the towing hitch. The vehicle manufacturer's specifications regarding trailer mass and max. vertical cup mass are decisive for driving whereat values for the towing hitch cannot be exceeded.

D-value formula:

$$\frac{\text{Max trailer weight [kg]} \times \text{Max vehicle weight [kg]}}{\text{Max trailer weight [kg]} + \text{Max vehicle weight [kg]}} \times \frac{9,81}{1000} = D \text{ [kN]}$$